



TECHNICAL DATA SHEET

Liferaft lighting Systems RL8 System

Daniamant design and manufacture all of our products in line with the relevant worldwide approvals, technical specifications, current legislation and International directives.

Our mission is to achieve World class performance through partnerships with our suppliers, customers and employees, providing products and services that enhance the safety and security of our customers.

Daniamant products cover 12 key areas:

- Lifejacket Lights
- Liferaft Lights
- Lifebuoy Lights
- Intrinsically Safe Lights
 - Special Lights
 - LED Flares
- Bridge Navigational Watch Alarm System (BNWAS)
 - Salinometers
 - Oil Level Alarm
- Electronic Inclinometer
- Forward Looking Sonar
- Agency for a range of world-renowned safety product brands (supplied to the Danish market)

Further Information

For further information on our products, please see our website: www.daniamant.com

MODEL	RL8 Internal	RL8 External
Part number. Daniamant Version ¹	46-011A	46-021-0650A
Colour – Body	Orange	
Light – Output	Minimum 0.5 cd	Minimum 4.3 cd
Light – Duration	Minimum 12 hours	
Light – Type	Steady	Flashing
Material	Polycarbonate	
Storage Temperature	-30° C to + 65° C	
Storage Life	5 years	
Operating Temperature	-30° C to + 65° C	
Weight – nominal	79 g	30 g
Battery Type	Lithium Iron Disulfide	No Battery
Activation	Automatic during Raft activation. Can be switched separately	
Approvals – Classification Societies	SOLAS/MED/USCG/TC/MER	
Approvals – Country	See our web site for full list of Country approvals	
¹ These Part numbers cover the Daniamant versions. OEM versions of these lights will have different part numbers, please contact the relevant company for details. ² The RL8 External Light can be, subject to quantities ordered, supplied with various lead lengths up to a maximum of 6.5 metres		

Transport Specification

Transport Regulations are subject to change. Please refer to the latest Product safety Data Sheet at www.daniamant.com for details.

Packing Specification

To minimize shipping costs, all RL8's are packed and supplied in boxes of 100 off.

The dimensions are:

RL8 Internal: Box of 100 off : 51 x 38 x 29 cm
 RL8 External: Box of 100 off: 25 x 25 x 25 cm

Approximate packed weights are:

RL8 Internal: Box of 100 off : 20 kg
 RL8 External: Box of 100 off : 6.5 kg

Daniamant Ltd
 Unit 3, The Admiral Park
 Airport Service Road
 Portsmouth, PO3 5RQ
 United Kingdom

Tel +44 23 92 67 51 00
 Fax +44 23 92 67 51 01
 sales@daniamant.com

Daniamant A/S
 Industrivej 24C
 3550 Slangerup
 Denmark

Tel +45 47 37 38 00
 Fax +45 47 37 38 09
 orders@daniamant.com

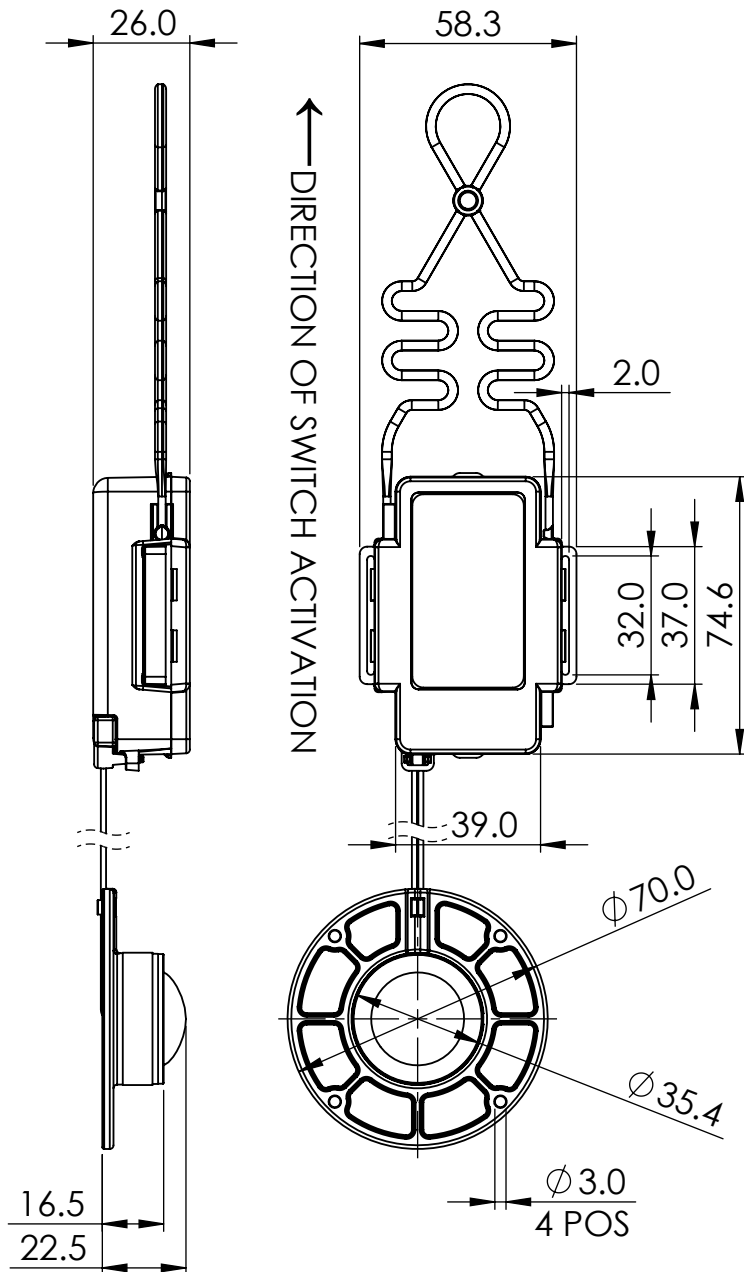

RL8