



TECHNICAL DATA SHEET

Lifejacket Light L12B Aquacel

Daniamant design and manufacture all of our products in line with the relevant worldwide approvals, technical specifications, current legislation and International directives.

Our mission is to achieve World class performance through partnerships with our suppliers, customers and employees, providing products and services that enhance the safety and security of our customers.

Daniamant products cover 11 key areas:

- Lifejacket Lights
- Liferaft Lights
- Lifebuoy Lights
- Intrinsically Safe Lights
 - Special Lights
 - LED Flares
- Bridge Navigational Watch Alarm System (BNWAS)
 - Salinometers
 - Oil Level Alarm
- Electronic Inclinator
- Agency for a range of world-renowned safety product brands (supplied to the Danish market)

Further Information

For further information on our products, please see our website: www.daniamant.com

MODEL	L12B Aquacel
Part number	56-A701
Plastic Colour	Clear
Light - Output	2 cd side beam, 3,5 cd vertical beam
Light - Duration	Minimum 12 hours
Dome - Type	Lens
Light - Type	Steady
Material	Moulded polythene
Storage Temperature	-30 C to +65 C
Operating Temperature	-1 C to +30 C
Storage Life	5 years
Weight - Nominal	80 g
Battery Type	Silver chloride
Activation	Water activated (pull cord)
Dimensions	106 x 31 x 22 mm
Approvals - Classification Societies	None
Approvals - Country	None
Nato Stock Number (NSN)	6135-99-433-5377

Construction

The L12B Aquacel consists of a moulded polythene case with four activation holes each sealed by moulded-in buttons. Inside, the case contains the water activated battery plates, which are connected internally to socket terminations at the top of the case. A cord is threaded through each of the fully sealed buttons so that they are removed in the correct sequence when the cord is pulled.

Operation

To activate, the buttons are removed by pulling on the cord and immersing the Aquacel in water. Once unsealed and in contact with water the Aquacel must be considered expended.

Transport Specification

The light is not subject to any transport regulations.

Packing Specification

To minimize shipping costs, all Aquacels are packed and supplied in boxes of 100 off.

The dimensions are:

Box of 100 off : 390 x 330 x 150 mm

Approximate packed weights are:

Box of 100 off : 8 kg

Daniamant Ltd
 Unit 3, The Admiral Park
 Airport Service Road
 Portsmouth, PO3 5RQ
 United Kingdom

Tel +44 23 92 67 51 00
 Fax +44 23 92 67 51 01
 sales@daniamant.com

Daniamant ApS
 Industrivej 24C
 3550 Slangerup
 Denmark

Tel +45 47 37 38 00
 Fax +45 47 37 38 09
 orders@daniamant.com

Daniamant Electronics A/S
 Industrivej 24C
 3550 Slangerup
 Denmark

Tel +45 47 37 38 00
 Fax +45 47 37 38 09
 info@daniamant.com

Outline

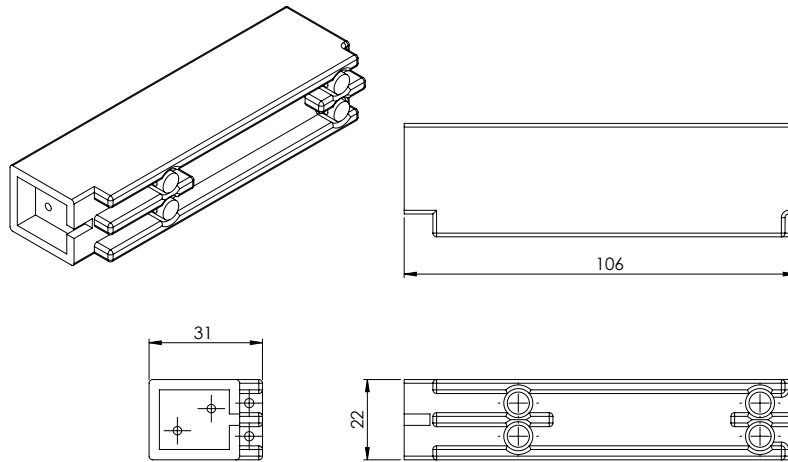

Discharge Graph

